

The hitch insert bracket shown can be used to mount the DuallyGuard to any 2" hitch. The bracket slips under the hitch insert, (the insert has the ball mounted to it) and using a 70"x1"x1" steel angle (included), the unit can be mounted to the hitch insert for easy removal and installation.

- 1) Cut out a rectangular opening (size hole as needed for your hitch) in the DuallyGuard using a utility knife to accommodate the hitch.
- 2) Align the pre-drilled holes in the DuallyGuard with those in the Angled Support Bar.
- 3) Attach the DuallyGuard to the angle support using the 1/4" - 20 - 1" nuts, bolts, and fender washers provided.
- 4) Mount the assembled unit to the hitch insert using the 5/16" bolts, nuts, and lock washers provided.

The DuallyGuard Kit Includes:

- 1 - 94" X 16" DuallyGuard
- 1 - 70" Steel Angle Support Bar
- 1 - Hitch Insert Bracket
- 10 - Fender washers
- 10 - 1/4"-20-1" bolts
- 10 - 1/4" nuts
- 4 - 5/16" nuts
- 4 - 5/16" bolts
- 4 - 5/16" split ring lock washers

You will need:

- 3/8" socket and ratchet
- 3/8" wrench
- Tape Measure
- Utility knife

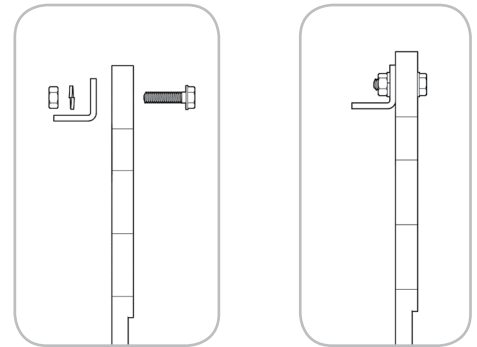
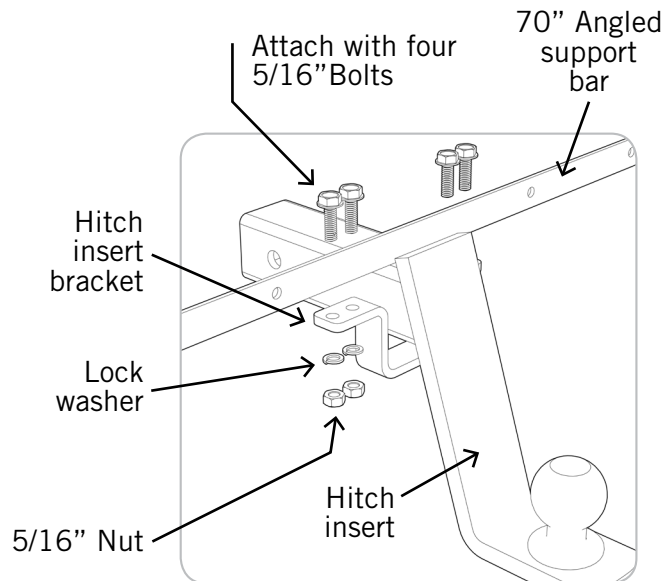

Side View: Installing the DuallyGuard to the support Bar using the set of 12, 1/4"-20-1" nuts and 1/4 washers and bolts.

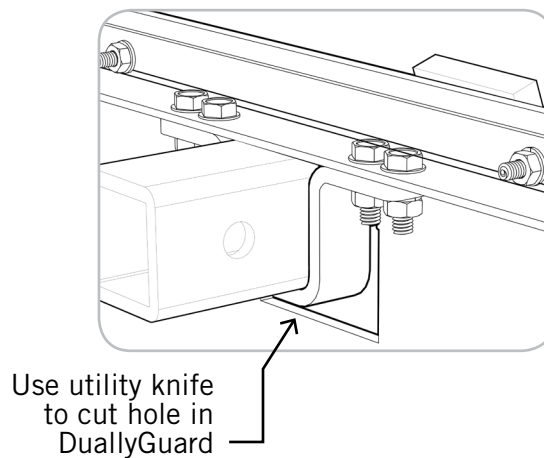

Assembled hitch insert bracket and support bar.

